



Find out about Methwold Old Vicarage's past...

Hello! Welcome to Methwold Old Vicarage. My name is George Turville. I lived here in 1642 with my mum Elizabeth and Reverend Stall, when I was 9 years old. Mum is Reverend Stall's housekeeper – that means that she does all the cooking and cleaning for him. She makes me help out too – boring! Does your mum make you do chores too?

We moved in here after my mum became a **widow** (say *wid-oh*). We go to the church called St George's just across the road - I'm sure I was named after it! When dad died, the Reverend felt sorry for us and offered mum a job as his live-in housekeeper. She doesn't get paid very much but at least we have somewhere to live, and quite a posh place too!

Our rooms are down one end of the house and Rev. Stall has the fancy rooms at the other end – the ones with the big, grand fireplaces. One of the jobs mum makes me do is clear the ash out of the fireplaces in the mornings. I get so messy doing it and once I got soot on the Vicar's rug – boy did I get a telling off that



Here's a picture of mum working hard.

Fact:

You become a **widow** when your husband dies. If your wife dies, you become a **widower**.

Mum works really hard all day long – she gets up before Reverend Stall and prepares his sitting room for him, opening the windows and letting the fresh air in, sweeping the rugs and dusting the window sills. It wouldn't be proper for her to do this whilst he was sitting in there – especially not if he has a guest!

Reverend Stall doesn't have a cook and so mum and me do all the cooking too. I don't mind helping so much with this and I'd quite like to be a cook myself one day. I just love taste testing all the food!

On Friday's we go to the market in the village and buy ingredients for cooking – I really enjoy going to market and seeing the different food you can buy. It seems like there's something new each week!

Where do you buy your food?



When I'm not helping mum with the household jobs, I go and play out in the Fens with my best friend Henry.

The Fens are a huge, flat area of fields and marshes. Henry and I pull our trousers up above our knees and splash about in the muddy water – mum hates it when I do this because the water makes me really smelly – it's filled with sheep and cow poo so it's really no surprise!

The Fens often flood and we even had to help a farmer rescue his sheep once! The farmer was worried about getting his clothes wet and the water was coming up over the special stilts he was wearing to keep himself dry. Henry and I didn't mind one bit, we just jumped in – what an adventure!

They are draining the Fens though so soon we'll lose our playground altogether. They say they need more fields to grow food. Why do the grown-ups always spoil the fun?!

What do you do for fun? Perhaps you'd like to draw a picture in the box below?

Fact:

Draining the Fens meant that cattle and sheep could be grazed on the drier fields and new crops could be grown. Drainage of the Fens started in 1629 but it wasn't until around the 1640's that it was more successful.

As the Fens dried up, the peat dried and shrunk. This caused the level of the land to fall and flooding from the sea became a big problem. Pumps were put into the fields to pump the water out again.



A farmer rescuing his sheep from a flooded field.



Unruly Rulers

Who were the Tudor and Stuart kings and queens?

This lot were a blood thirsty bunch, always chopping off heads. **Tudor** and **Stuart** are the family names of the kings and queens. The first Tudor was Henry VII in 1485 and they lasted till Elizabeth I. Then the Tudors' cousins, the Stuarts, ruled from James I to Anne.



King Edward VI

Henry VIII's only son, he had some big shoes (and clothes) to fill! King at nine and dead at 16. Poor Eddie.

1509

King Henry VIII

6 wives, only 1 son. Angry at the Pope horrible Henry made himself Head of the Church destroying all the Catholics churches.



1547

Lady Jane Grey

Only 16 when she became Queen for just 9 days before Mary Tudor took the throne. Off with her head!



1553

Queen Mary I

Back to Catholics again. Bloody Mary was her name, burning Protestants was her game.

1553

Queen Elizabeth I

Good Queen Bess knew leaving religion alone was best. (Unless the Catholics attacked!) Had lots of boyfriends but married none.

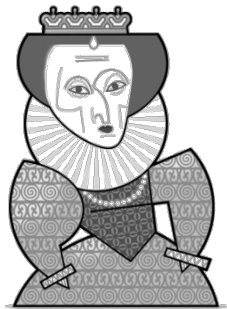

1558

King James I

What a silly king, he kept thinking witches were trying to kill him! He even wrote a book on witches.

1603

King Charles I

Bad King Charlie wanted to rule without Parliament. That started a civil war which he lost. Onto the block went Charlie's head. One chop and he was dead.



1625

Oliver Cromwell

Not a king but still a ruler. He didn't like the royals and made himself Lord Protector of England. He didn't last too long.

1649

King Charles II

A merry monarch who brought back fun and games Oliver had banned!



1660

King James II

A bit dim was this king. He tried to make everyone Catholic again, then ran away when they said no.

1685

Queen Mary II & William III

She and her husband took her dad, James II's throne in the Glorious Revolution. Not so glorious for James.



1688

Queen Anne

A sickly queen who loved to eat!

1702-1714





Meet Charles I

– who ruled when this George was living at Methwold Old Vicarage.



Hi Charlie!

So when did you become king?

I became King on the 27 March 1625 when I was 24.

What are you most famous for?

When I lost the Civil War Parliament had my head chopped off.

What is your favourite thing to do?

I loved collecting art. I had over 1760 famous paintings!

What is the naughtiest thing you've ever done?

I ruled without Parliament for 11 years. I'm the king so I can do what I want – why should I have to listen to anyone else?

Design



What does Methwold Old Vicarage look like?

Can you walk all the way around it?

Can you use any of these words to describe the building? Draw a circle around the ones that do.

Does Methwold Old Vicarage look similar to nearby buildings?

Castle

Pretty

Stone

Symmetrical

Square

Friendly

Tall

Industrial

Brick

Home

Elegant

Low

Methwold Old Vicarage was built in the late 15th Century as a two-storey **jettied** house. It's an early example of a move away from the traditional layout of **medieval** (say *med-ee-eval*) 'hall houses'. A hall house had one large room in the middle of the house, open to the roof with a central **hearth** (fireplace).

It was very unusual for houses built around this time to have fireplaces and chimneys, but Methwold Old Vicarage may have had as many as three **flues** (say *fl-oo*).

The brickwork on the end gable and chimney is also very fancy for the time – most houses built in these times were timber-framed with mud, straw and sometimes pony poo filling in the gaps.

Why such a grand house was built for a priest in a small village, we still don't know. Why do you think this beautiful house was built?

Facts:

Jettying was a popular building technique in the 1500's – it meant that you could create extra space in the upstairs rooms of your house without obstructing the street. It also sheltered the lower walls from the weather.

A **flue** (say *fl-oo*) is the channel behind a fireplace where the smoke draws up and out of the chimney.

A **gable** is the triangular upper part of a wall at the end of a ridged roof.



Do you see how the second floor over-hangs the first? This is jettying.



Buildings are quite easy to draw. They are usually made up from lots of geometric shapes, like squares, triangles and circles.

Have a go at drawing Methwold Old Vicarage. Have fun drawing its fancy chimney!

Please tell an adult where you are going so they don't worry about where you are!

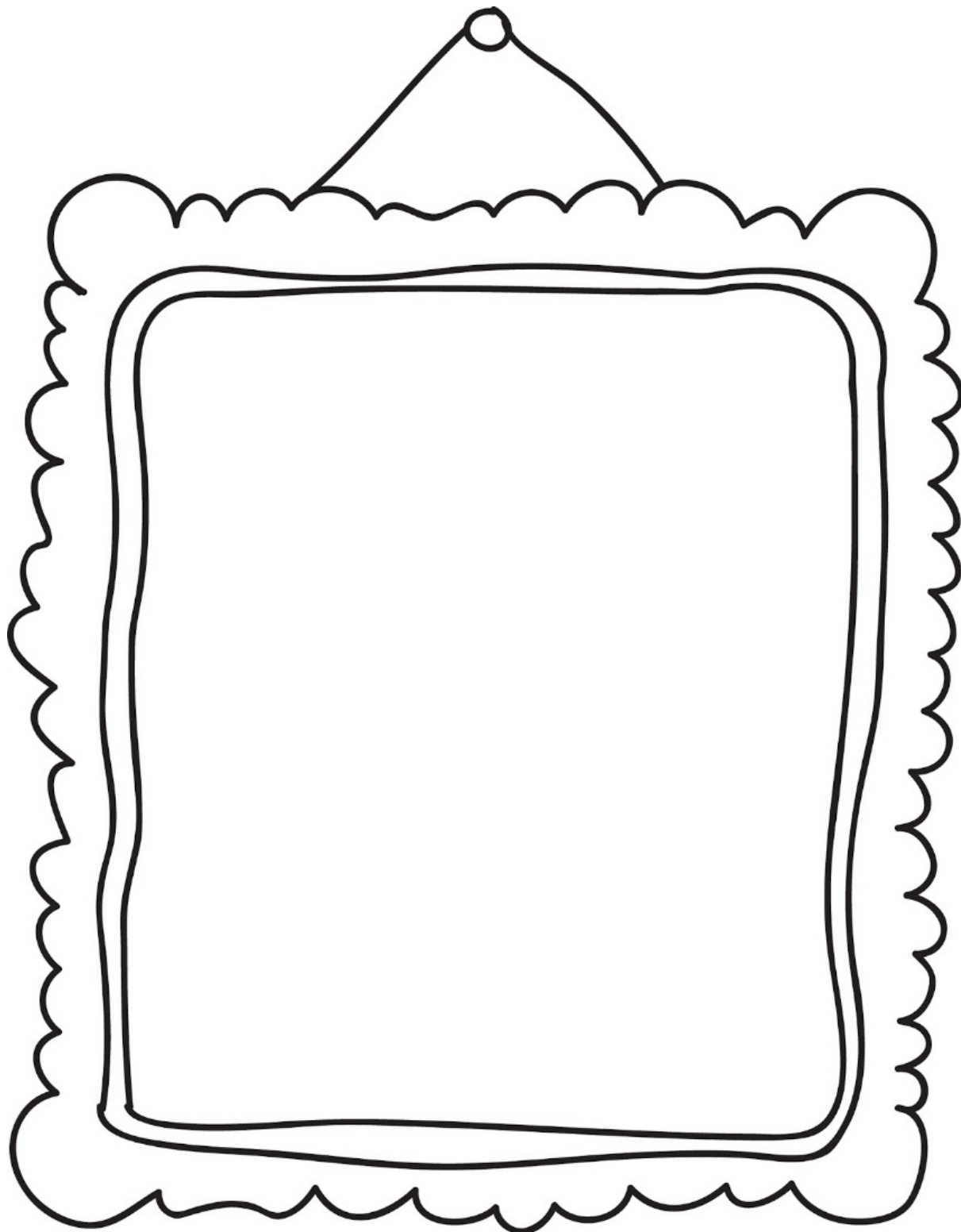



What is Methwold Old Vicarage built from?

Fact:

The simplest house frame was a Cruck. A curved tree was cut in two pieces along its length. You needed one cruck at each end of the building and one in the middle. This created your frame, which you then added to and filled in with mud walls and a straw thatched roof.

A Cruck frame was quick to build but it had not much room upstairs.

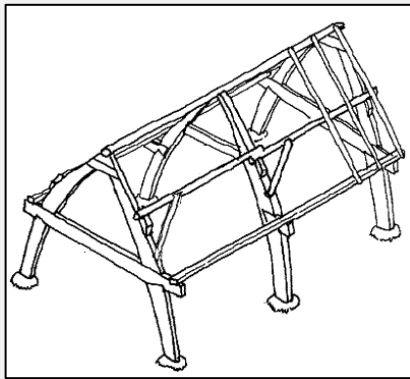

Methwold Old Vicarage is built with a wooden frame, infilled on the gable end with brick. Buildings with wooden frames are quite rare today. Most were pulled down to make way for more modern building. They caught fire easily too. Timber houses were quick and cheap to build (timber is wood used for building).

The timber from Oak trees was the best for building because it is very hard. Oak is a common tree in Britain, and it was grown especially to supply timber for building – not just houses but ships too. You can still see big oak trees in the countryside today. They look like this, and they have wiggly leaves and acorns in the autumn.



Next time you go for a walk, see if you can spot an oak tree. Look out for its acorns too!

People who work with wood are called carpenters.

Over time, timber framed houses started to look more like boxes, with a triangle for the roof. People wanted to have proper rooms upstairs.

This is a picture of Langley Gatehouse, also owned by Landmark. The carpenter has made lovely patterns inside the basic box frame as decoration (say 'dec-or-ayshun').





The walls between the sections of timber frame were made of mud, with bits of straw and perhaps a bit of cow or pony hair – or even poo!

If the grid below is your timber frame – design a pattern to make it more decorative. The carpenters were clever people and could make curves out of straight pieces of wood – so you can be as creative as you like! You can add windows and doors if you like.

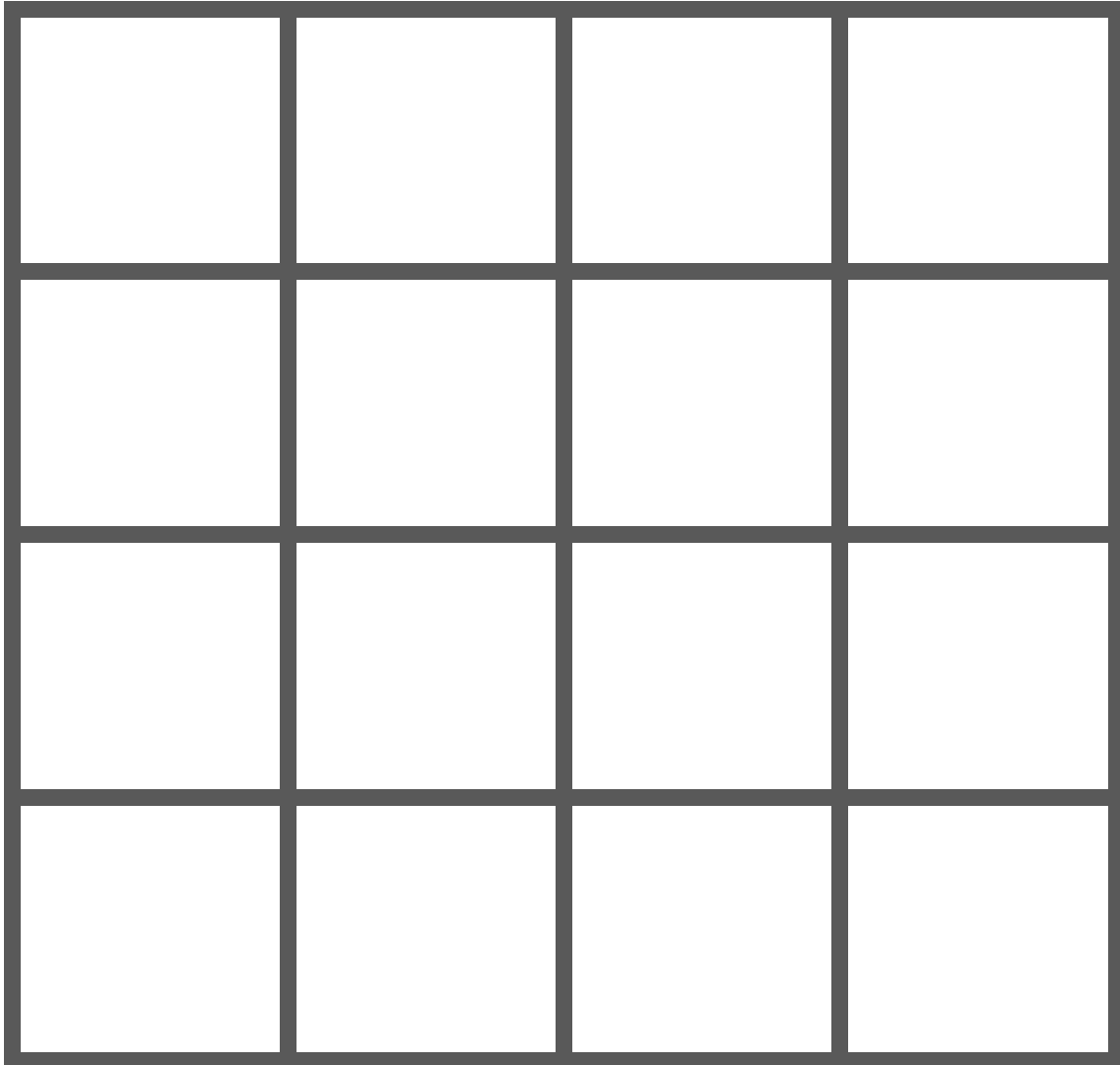

What other building materials can you find outside and inside Methwold Old Vicarage?

Circle what you can see and note down where you found them.

Stone

Glass

Wood

Plastic

Metal

Clay

Flint

Concrete

Brick

Ceramic



The size and shape of windows tells you a lot about the age and style of the building. What type of windows does Methwold Old Vicarage have?

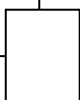
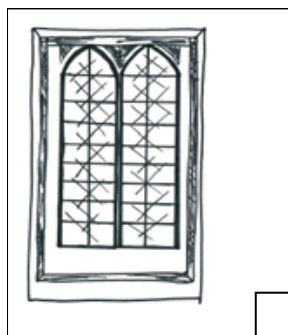

Fixed Picture

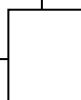
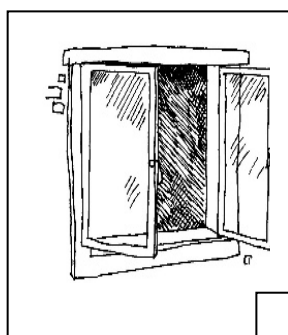

Casement

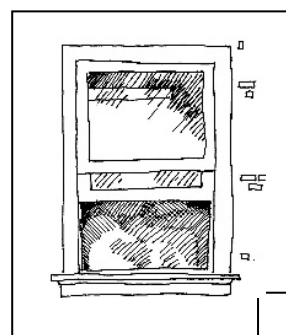

Sash

Fact:

Have you seen that in some very old buildings the windows don't open? Imagine how hot it got in the summer! When the casement window was invented it was the first type of window to open.

Entrances can be grand or simple. What is the front door of Methwold Old Vicarage like?

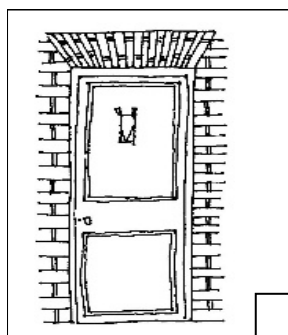

Doorframe

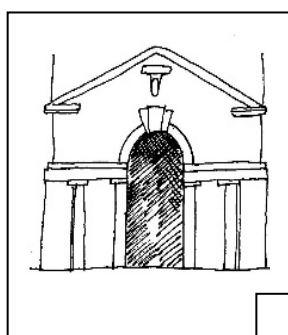

Porch

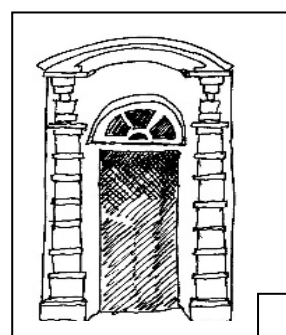

Canopy

There are many different styles of staircases. Which style is closest to the staircase at Methwold Old Vicarage?

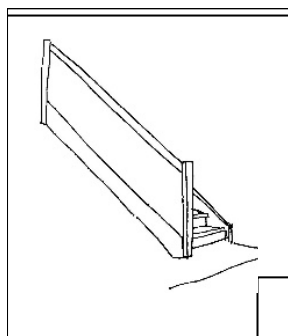

Straight

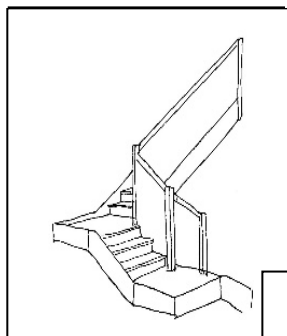

Quarter turn

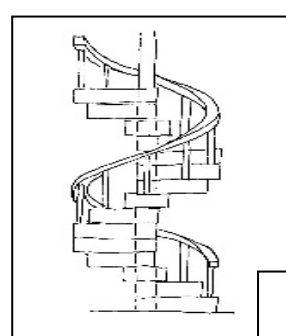

Spiral



What is Methwold Old Vicarage's special gable end built from?

Fact:

The earliest bricks date back to about 7,500BC and were made of mud. The mud was packed into wooden moulds. They were then turned out and left to dry in the sun until they were hard. The first fired bricks were made around 3,000BC. Fired bricks are harder and last longer in wetter climates.

Today we make bricks in factories by mixing together clay, sand and lime. This mixture is poured into a mould, dried and then fired in an oven at 1100 degrees.

Bricks have a long and a short face like this.

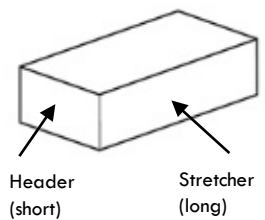

They are arranged in layers, or courses which have different patterns.

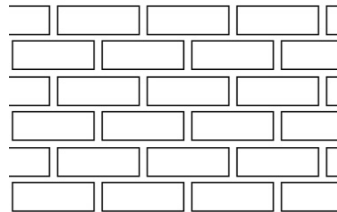

Stretcher bond

The simplest bond to lay – using the long face of the brick.

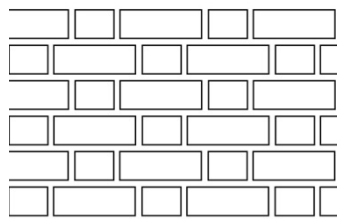

Flemish bond Bricks are laid with one header and one long face.

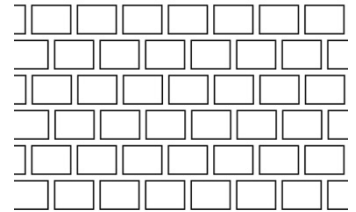

Header bond

The bricks are laid with the header facing outwards. The header is the end of the brick.

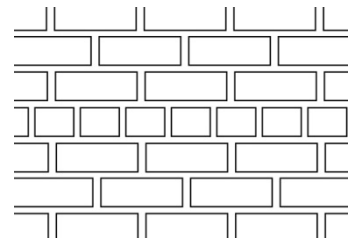

English bond

Three rows of long face and one row, of headers.

Try colouring in the short end on the brick patterns above, so you can see the pattern.

Some architects and builders were a bit more creative and designed very beautiful walls like these ones here. They used different coloured bricks to make these patterns.

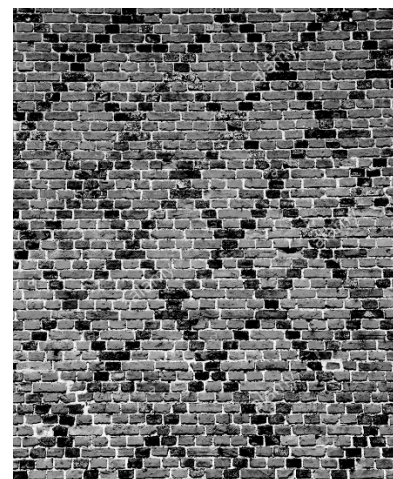

Quest



Discover more about Methwold Old Vicarage

Methwold Old Vicarage has seen many changes since it was first built over 500 years ago! Follow this quest to discover more about it.

Go into the garden and take a close look at the brickwork on the north gable. This wall is what is called a **showpiece**. Did you know that there are no other walls in Norfolk like this?



Fact:

A **showpiece** is something to show off your skill and which attracts attention – in this case brickwork. Can you see how the builder is trying out different patterns?

Go into the sitting room and look up at ceiling. The carving on the central beam is called **ribbon moulding** (say *mole-ding*). The detail on the beams shows us that this house was built for somebody with a lot of money or who was very important. Have you spotted any other things which suggest the same? Perhaps the unusual brick work surrounding the fireplaces?



Have you seen the amazing wall paintings in the bedrooms? They were painted in the late 1500's. They are repeated leaf patterns in black, white, red and yellow. Wall paper didn't exist then.

Why don't you have a go at creating your own repeating



Living in Methwold Old Vicarage

The floorplan of a building is a map of the rooms. Methwold Old Vicarage has two floors. The plans below show you the shape of each room. Take a walk around each floor. Can you identify the rooms and write on the plan how they are used today?

Ground Floor

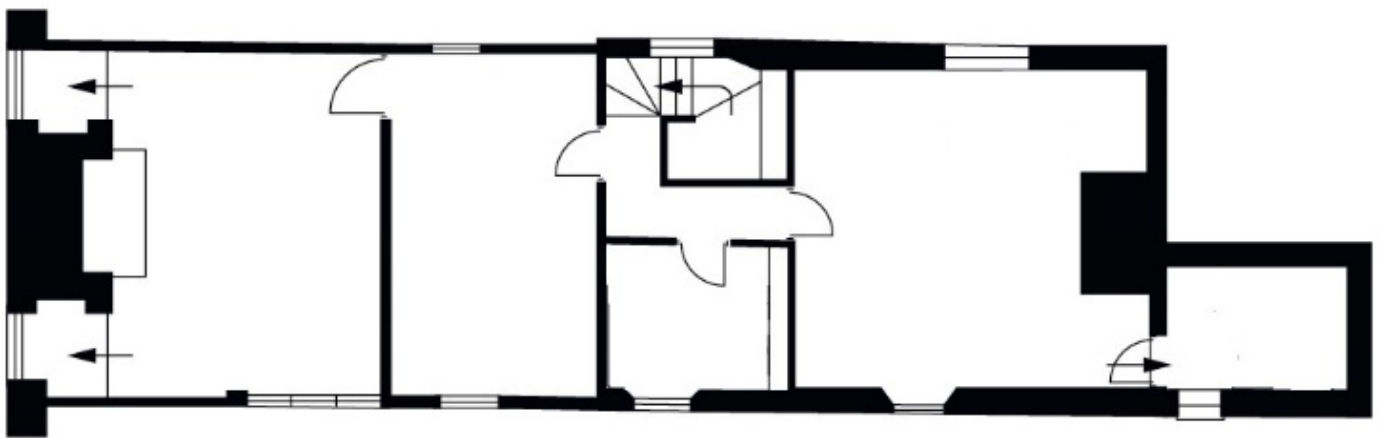
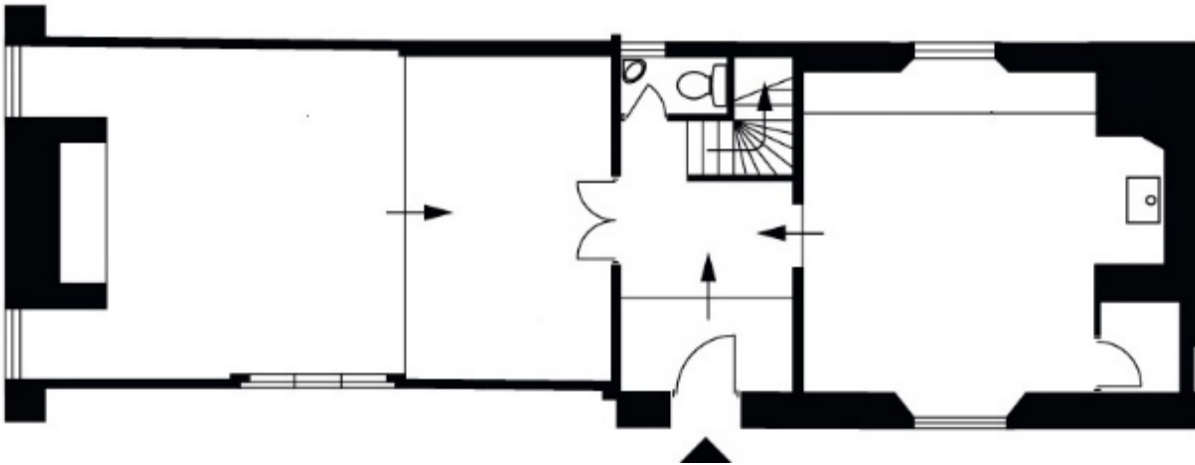

First Floor

We use these symbols to show where beds, tables and bathrooms are. Add the symbols on to the floorplans to show where the furniture is.



Bed

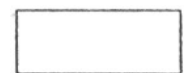

Rectangular (or a round) table



Bathroom



Cooker



Sofa

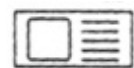

Kitchen sink



Can you find an example of each of these things inside Methwold Old Vicarage. Describe, or draw the object when you find it.

Your favourite piece of furniture

The fireplace (is it an open fire or does it have a stove?)

The wall painting design

Fact:

The wall paintings were painted in about 1580. They were painted using pigment colours from dyes which could be grown or found in rocks and soil. Wallpaper hadn't been invented yet so many large houses of this age had similar wall paintings.

In the space below, draw the view from your bedroom window. What can you see? The church, or perhaps you can see as far as the Fens?



Can you answer these questions correctly?

1. What are the Fens?

Curtains Large, boggy fields

An animal A person who works for
the church

2. Who was on the throne when George moved in to the Vicarage?

(Psst... check Unruly Rulers!)

Elizabeth I

James Bond

Oliver Cromwell

Charles I

3. When were the wall paintings added to the bedrooms at Methwold?

1580

1680

1780

1880

4. What was a medieval hall house?

A house with a large
central hall

A type of church

A house with a large
entryway

A type of castle

5. What material is the north end gable made from?

Stone

Clay

Brick

Wood

6. What is jettying?

Jet Skiing

A type of drink

A computer
programme

A building technique

7. The main beam in the sitting room is decorated with what kind of moulding?

String

Bow

Ribbon

Cloth

8. Which colour does NOT feature on the wall paintings?

Blue

Yellow

Red

Black

To find the answers skip two pages...



Peake's House Word Search

Now have a go at the word search. Think about different parts of the building when filling in the word search. The words to find are at the bottom of the page.

B	S	N	B	T	K	E	D	R	K	V	S	D
E	Y	S	H	I	C	C	L	I	Y	R	W	S
Q	E	B	B	M	A	A	S	B	H	E	O	K
R	Z	E	S	B	T	L	H	B	A	P	D	C
W	D	A	D	E	S	P	O	O	L	E	N	I
X	U	M	F	R	Y	E	W	N	L	E	I	R
U	N	S	A	F	E	R	P	M	H	K	W	B
G	A	C	U	R	N	I	I	O	O	E	N	G
B	I	V	W	A	M	F	E	U	U	S	O	Z
V	J	T	U	M	I	J	C	L	S	U	R	X
E	V	U	N	E	H	B	E	D	E	O	F	H
H	C	R	U	H	C	G	Y	I	T	H	O	N
G	N	I	Y	T	T	E	J	N	T	V	L	W
T	H	E	F	E	N	S	A	G	B	A	K	N
G	N	I	T	N	I	A	P	L	L	A	W	S

TIMBER FRAME

WINDOWS

HALL HOUSE

CHIMNEY STACK

CHURCH

JETTYING

NORFOLK

FIREPLACE

WALL PAINTING

THE FENS

RIBBON MOULDING

BRICKS

VICAR

HOUSEKEEPER

BEAMS

SHOWPIECE

How many of these words did you find? Put your score in the box.

16



Answer sheet:

Woodland quiz answers:

1. Large, boggy fields
2. Charles I
3. 1580
4. A house with a large central hall
5. Brick
6. A building technique
7. Ribbon
8. Blue

How many did you get right?

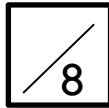

Fact:

Did you know that the chimney stack at Methwold is octagonal? This means that it has eight sides. The stack is split into five 'zones' by bands decorated in different patterns.

Impress the grown-ups with these Norfolk facts...

Did you know that Norfolk has 659 medieval churches – that's more than any other place in the world! 124 of these churches have round towers – no other county in England has that many.

The Norfolk coast runs for almost 100 miles – I wonder how long it would take you to walk it!?

The largest and best-preserved mammoth (that's a giant elephant) skeleton ever found was recovered from cliffs at West Runton in Norfolk. The only bones missing had been eaten by hyena. Yes, really!

It's said that the fish finger was invented in 1955 in the seaside town of Great Yarmouth in Norfolk. I like to eat mine in sandwiches! How about you?

In medieval times, Norwich was the second biggest city in England, after London. It's the only city to have fewer people living in it now than it did back then!





Bake a honey cake

In the 1600's, honey cakes were a treat. You'd buy them at fairs or on special holidays. Honey was used to make things sweeter as sugar came from the Middle East (and later Europe) and was very expensive.

Here's a simple recipe for you to try. You might need the help of an adult.

250g clear honey, plus extra 2 tbsp to glaze	100g dark muscovado sugar
225g unsalted butter	3 large eggs, beaten
	300g self-raising flour

Remember to pre-heat the oven: fan 140 °C or electric 160 °C: Gas 3

- Butter a 20cm round cake tin and line it with baking paper
- Cut the butter into pieces and drop them into a medium pan with the honey and the sugar, let it melt slowly
- When the mixture looks like liquid, turn up the heat under the pan and boil for about 1 minute
- Leave to cool for 15-20 minutes (important - this stops the eggs cooking when they are mixed in!)
- Beat the eggs into the melted honey mixture using a wooden spoon
- Sift the flour into a large bowl and pour in the egg and honey mixture. Beat until you have a smooth, quite runny batter
- Pour the mixture into the cake tin and bake for 50-60 minutes. You can tell it's ready as it will be golden brown and spring back when pressed. Push a skewer into the centre of the cake and it should come out clean.
- Turn the cake out on a wire rack
- Warm 2tbsp honey in a small pan and brush over the top of the cake to give it a sticky glaze, then leave it to cool.
- If you want, serve with vanilla ice cream! This is making me feel hungry...



Make a woodland origami fox

Woodlands have lots of different animals living in them from rabbits, mice and insects to deer, birds and foxes. Have a go at making your own origami fox with the paper on the next sheet.

You will need:

- Paper
- Scissors
- Colouring pencils

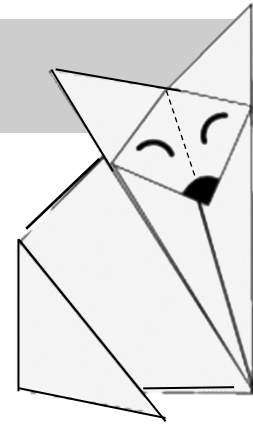

Step One:

Cut the A4 piece of paper into a square. Follow the dotted lines on the sheet on the next page.

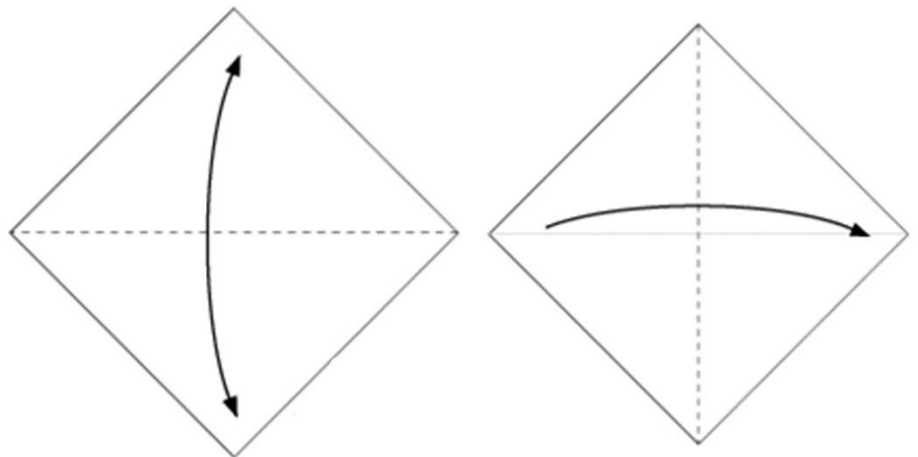

Then fold in half one way to make a crease, then open it up and fold it in half the other way.

Step two:

Fold both sides in to make a diamond shape.

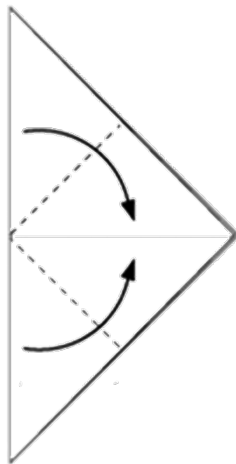

Step three:

Once you have the diamond shape, fold the paper in on itself in half again so that all the flaps are on the outside edge.

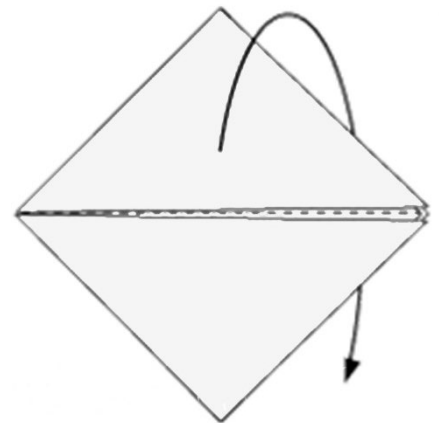

Step four:

Fold the first flap back a little bit like in the diagram to make a fox ear.

Then with the middle flap push it inwards to make a Diamond shape that will be the fox's face.

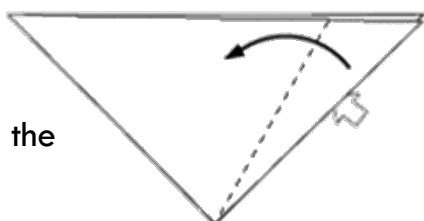
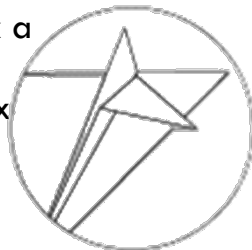

Step five:

Turn the paper round so that it is at a right angle. Then fold the other corner inwards to create the fox's tail. Then colour and draw in the fox's face!

