

History



Find out about Llwyn Celyn's past...

Hello! Welcome to **Llwyn Celyn** (say *clew-in kell-in* - hard eh? In Welsh, some letters sound different than in English). Llwyn Celyn is 600 years old!

My name is Job Watkins and I was 10 years old in 1706 when Llwyn Celyn was already 286 years old. That's over 600 years before your time! I lived here with my uncle William, his family and my father Thomas.

Our family farmed the land surrounding Llwyn Celyn – a total of 116 **acres** if you count what Uncle Will had up on the hill too! That's a lot of ground to cover, we had no quad bikes or tractors like the farmers use nowadays so we had to walk miles and miles every day. My feet were so sore some days I thought they'd fall off! Alright for the grown ups who could ride horses or ponies...

When we moved in here, the house looked a lot different to how you see it today. It was Dad and Uncle Will who put the new ceiling in the main hall – they still tell stories about how it was a tough job and there was much moaning and many splinters! They also built the big new chimney stack and bread oven. What you see today is their “modernisation” of Llwyn Celyn.



Fact:

An **acre** is an area of land which totals 4,047 square meters. A football pitch is 7,140 square meters. If the Watkins farmed 116 acres in total, that's almost the same as 66 football pitches – wow! Can you do the maths yourself?

Dad and Uncle Will liked playing ‘Lord of the Manor’ so much they built a huge table out of oak so they could sit at it and feel all important.

The table was gigantic – it was 13 ft long and all hand-made. We were all very proud of it and it was great for feasts or harvest supper.

Do you have a dining room table at home? What's it like?



The Watkins' table, was made in 1690 and stayed at Llwyn Celyn till the 1940s.



The Farming Year

I hated winter on the farm – it was always so cold, and my fingers often turned blue when I was working outside. One of my jobs in the winter time was to crack the ice on top of the troughs so that we could drink the water and wash in it. We didn't have taps so we washed in the water which came down from the hills and filled the trough. Don't tell anyone but I always used to pretend I'd washed when I hadn't. I didn't want that freezing cold water anywhere near my skin! I must have been very smelly but I'd rather that than turn to ice myself and I'm pretty sure that everyone else on the farm did the same thing! Phew-ee!



Llwyn Celyn dusted with snow during Landmark Trust's restoration

My favourite time of year on the farm was springtime – that's when the lambs were born. I had a favourite ewe (that's a female sheep) who I called Baabaara - get it?! She was left an orphan when she was born so I raised her, feeding her from a bottle – I think she thought I was her dad or mum!



The busiest time of the year was harvest time. I enjoyed this time of year because other boys from nearby farms were sent to help us to harvest the crops and then we'd be sent to their farms to help them too.

I liked seeing how differently each farm did things and taking tips back to my family. At the end of the harvest Dad and Uncle Willie would hold a big feast around the giant table – we'd eat lots of yummy food and the grown-ups would drink the cider which they'd made. I tried the cider one year but didn't like it much - it made my head feel funny!





Who was Glyn Dwr and why was he important?

Owain **Glyn Dwr** (say *Glin-door*) was born in 1349 to a rich family in northeast Wales. In 1399 he started a fierce **revolt** against Henry IV and the English rule of Wales. If he'd won, he'd have been King of Wales.

The uprising was quite successful in the beginning and quickly took control over large areas of Wales including Llanthony Valley where Llwyn Celyn sits.

However, Glyn Dwr's army didn't have the weapons needed to defend the castles and ships they captured, so they soon lost control of them once again.



Owain Glyn Dwr

Llanthony Priory was loyal to the English crown and the prior paid £13 to help pay for English relief forces to help end the revolt – a lot of money then!

The revolt ended in 1415 when Glyn Dwr's died, but both sides had destroyed much of Wales by then.

Llwyn Celyn was built in 1420 in the recovery period following the revolt.



Owain Glyn Dwr's seals – they showed him as a mighty warrior and wise ruler.

Why did Glyn Dwr revolt?

Glyn Dwr had fallen out with Lord Grey of Ruthin over some land. He took on the title of 'Prince of Powys' – how grand – and with a small group of followers, attacked Lord Grey's lands. From there the revolt snowballed; Glyn Dwr made an agreement with the French, and a family called the Percys, to divide the United Kingdom into three. Bold, eh?

It was all going quite well for Glyn Dwr until the Earl of Warwick defeated him in 1404 and the Welsh forces had to retreat down the Usk Valley – that's very near here.

Glyn Dwr was driven from his last strongholds around 1409. He was never captured despite big rewards offered by Henry IV; the Welsh never betrayed him.

Fact:

A **revolt** is a rebellion or uprising against a ruler or government in order to gain control.



Evacuees at Llwyn Celyn...

During the Second World War children were **evacuated** (say ee-vac-u-ated) from their homes in big towns which were at risk of being bombed, to the countryside where they would be safer.

On the 2nd of June 1940, brothers John and Richard Gilden, were evacuated from their home in Folkestone, Kent to the Welsh valley where Llwyn Celyn sits.



Children left their parents in the War and were put on trains to the countryside with their name on a label and just a small bag of their things. Would you be excited to go on an adventure or scared to leave your home?

The brothers had to go to the small school up the hill from Llwyn Celyn – there were no pens or paper, just slates to write on. Back then teachers thought that all pupils should be right handed and as John was a leftie, he often got whacked with a ruler and told to write with his right hand – oww! Does that sound fair? Are you left or right handed?



John Gilden at Llwyn Celyn in 2018 – almost 80 years after he first arrived.

Facts:

Rationing was an allowance given by the government. During the war when food supplies were low everything was shared out equally in small amounts. Things like sugar, tea, biscuits, butter and meat were restricted to just a few ounces a week. For example each adult was only allowed 2 ounces of butter a week – that's probably just enough to spread on your toast a couple of days a week! Everyone was given coupons to swap for their ration.

The 'vacee's' were lined up along a wall in Cwmyoy (say kwum-yoi) village hall and local families had to pick which child would come to live with them.

Richard was a strong 14 year old and the Jaspers, who lived at Llwyn Celyn at the time, picked him to help out on their farm. Richard wouldn't leave his little brother John and so the Jaspers took them both in.

* *

During the war things like petrol, soap and some types of food were **rationed** and John remembers the government putting a special dye into agricultural fuel, which was to be used in the tractors to plough the fields, so that you couldn't use it in your normal car!

The government allowed each farm to have two pigs which would be used for meat. John says, the pigs at Llwyn Celyn were huge and the family often enjoyed bacon. The farms in the area used to share parts of their pigs or sheep with each other so that everyone could enjoy the meat. It sounds like there was a great community spirit in spite of the war!

Unruly Rulers

Who were the Tudor and Stuart kings and queens?

This lot were a blood thirsty bunch, always chopping off heads. **Tudor** and **Stuart** are the family names of the kings and queens. The first Tudor was Henry VII in 1485 and they lasted till Elizabeth I. Then the Tudors' cousins, the Stuarts, ruled from James I to Anne.



King Edward VI

Henry VIII's only son, he had some big shoes (and clothes) to fill! King at nine and dead at 16. Poor Eddie.

1509

King Henry VIII

6 wives, only 1 son. Angry at the Pope horrible Henry made himself Head of the Church destroying all the Catholics churches.



1547

Lady Jane Grey

Only 16 when she became Queen for just 9 days before Mary Tudor took the throne. Off with her head!



1553

Queen Mary I

Back to Catholics again. Bloody Mary was her name, burning Protestants was her game.

1553

Queen Elizabeth I

Good Queen Bess knew leaving religion alone was best. (Unless the Catholics attacked!) Had lots of boyfriends but married none.



1558

King James I

What a silly king, he kept thinking witches were trying to kill him! He even wrote a book on witches.

1603

King Charles I

Bad King Charlie wanted to rule without Parliament. That started a civil war which he lost. Onto the block went Charlie's head. One chop and he was dead.



1625

Oliver Cromwell

Not a king but still a ruler. He didn't like the royals and made himself Lord Protector of England. He didn't last too long.

1649

King Charles II

A merry monarch who brought back fun and games Oliver had banned!



1660

King James II

A bit dim was this king. He tried to make everyone Catholic again, then ran away when they said no.

1685

Queen Mary II & William III

She and her husband took her dad, James II's throne in the Glorious Revolution. Not so glorious for James.



1688

Queen Anne

A sickly queen who loved to eat!

1702-1714





Meet King William III **– who ruled when this Job Watkins was born at Llwyn Celyn .**



Hi William!

So when did you become king?

Myself and my dear wife Mary jointly took the throne 1689 but Mary sadly died in 1694 so I reigned solo after that.

What are you most famous for?

Stealing the crown from Mary's father, James II, in the 'Glorious Revolution'!

What is your favourite thing to do?

I love horse riding, although I am prone to falling off! (This ultimately led to Williams's death in 1702 after he fell off and broke his collar bone!)

What is the naughtiest thing you've ever done?

I'm not proud of it but I had an affair with one of Mary's ladies in waiting!



Llwyn Celyn through the ages...

Llwyn Celyn was built in 1420. That's almost 600 years ago! Experts worked out when it was built using a technique called **dendrochronology** (say *den-do-cron-ol-ogee*) together with **oxygen isotope analysis**. It was once part of the Llanthony Priory estate. The fancy decoration over the doors and its layout suggest it may even have been built for the prior himself!

Henry VIII kicked all the monks out of Llanthony Priory in 1538 and grabbed its lands for the Crown. In 1546 a rich lawyer called Nicholas Arnold bought the estate. He rented it out to farmers.

By 1690 the Watkins family were renting Llwyn Celyn and they decided to modernise it. William Watkins, or perhaps his brother Thomas, put a ceiling in the main hall, – this made an extra large room upstairs.



This doorway was uncovered during the restoration – perhaps it led to the original staircase to the upper rooms?

Facts:

Dendrochronology is the science of dating something by the wood it's made of. Normally you count the growth rings in timber and tree trunks. Each ring is a year: in wet years the tree grows faster than in dry years.

Have you ever counted the rings on a branch or tree stump to see how old the tree was? It's the same technique!



At Llwyn Celyn, this didn't work so **oxygen isotope analysis** was done instead. This works out the levels of oxygen in the air while the tree was growing. They can then work out which time period it grew in, and when it was cut down. Clever stuff, right?!

The Watkins also put in the large chimney stack and bread oven which you can see in the dining room today. This bread oven was discovered when Landmark took out the 20th century fireplace.

Turn the page to see what Llwyn Celyn would have looked like when it was built and where the Watkins made their changes.



A medieval building project...

Let's think about how old Llwyn Celyn is:

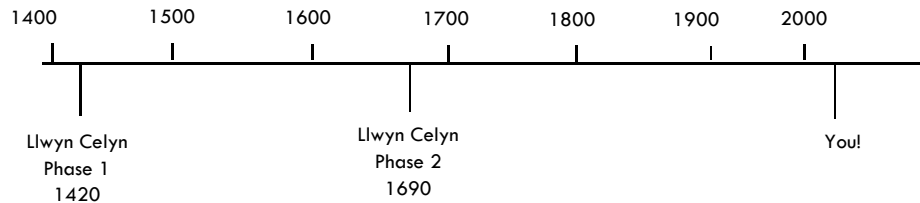

Llwyn Celyn was built in two main stages.

1. 1420 All the walls and roofs and timber frame – but no chimneys!
The **hall** was just one big open space with the roof for its ceiling.
The **solar** did have two floors all along, and also showed off its roof.
2. 1690s To get more rooms, a ceiling was put into the hall, and an enormous chimney stack so there was less smoke! A staircase was added beside it to get upstairs.

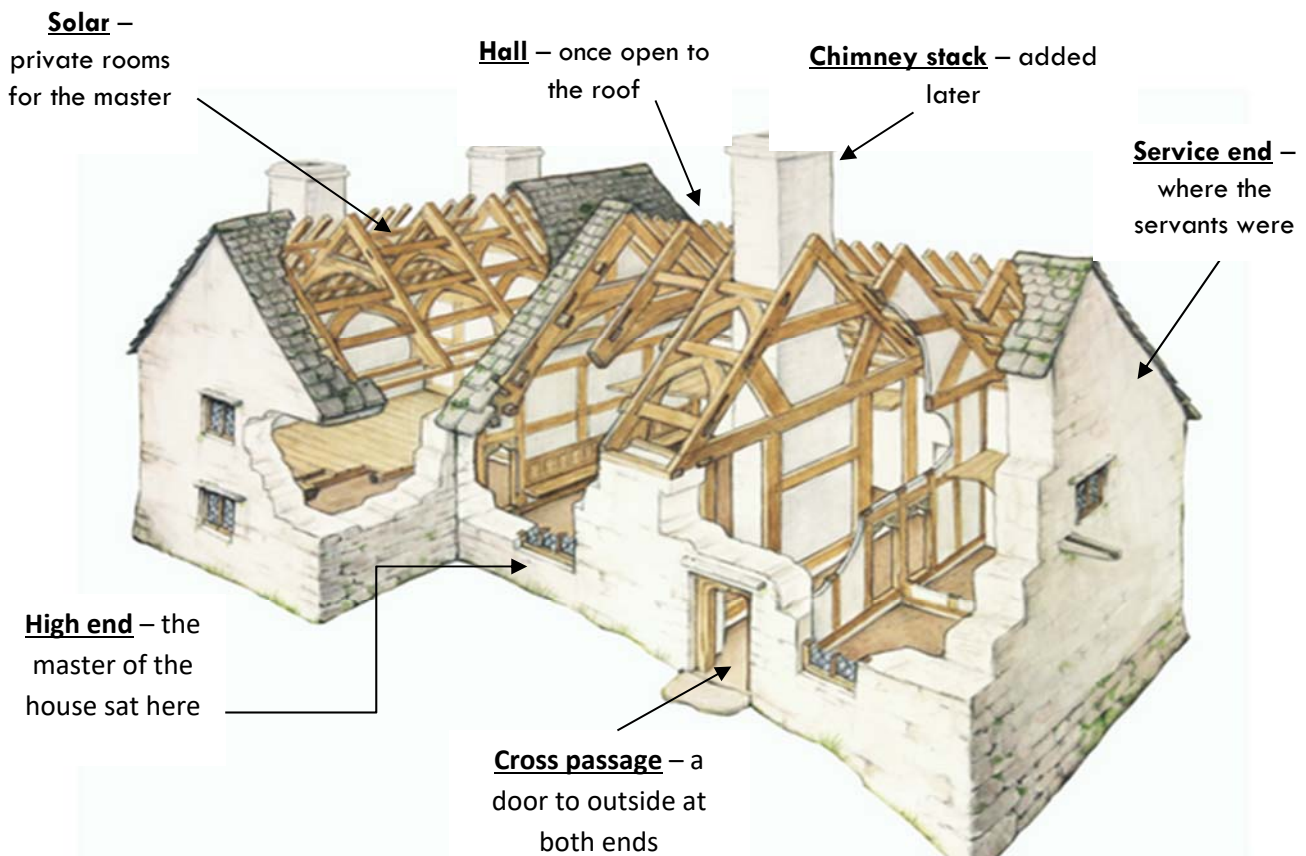

Facts:

Hall: in medieval times everyone lived in one big room with a fire on the floor in the middle. The smoke found its way out through the roof – but it must have been very smoky!

Solar: this means the private rooms for the master of the household and his family.



Buildings are quite easy to draw. They are usually made up from lots of geometric shapes, like squares, triangles and circles. **Have a go at drawing Llwyn Celyn.** Will you choose the front or the back?

Please tell an adult where you are going so they don't worry about where you are!

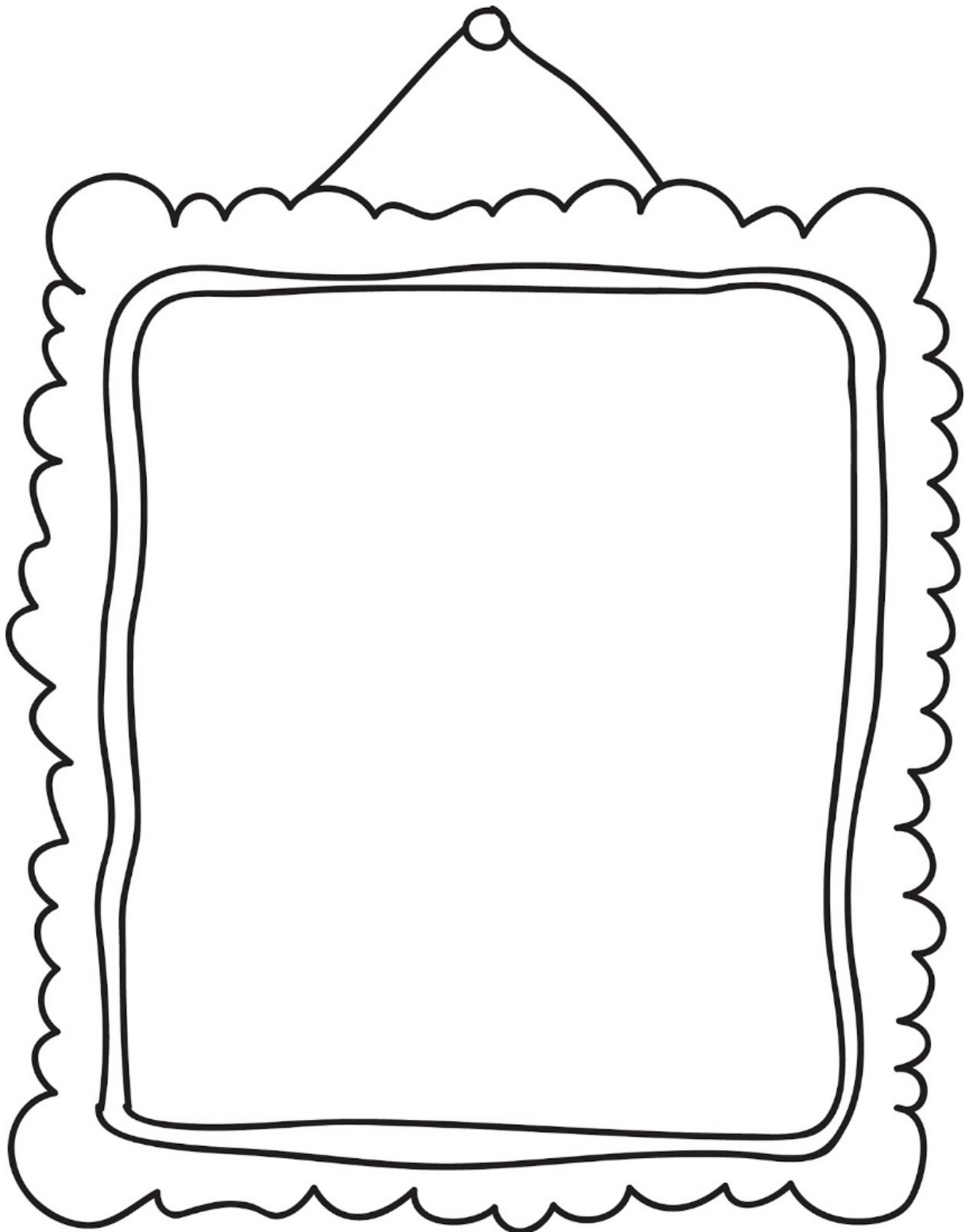



What is Llwyn Celyn built from?

Fact:

The simplest house frame was a Cruck. A curved tree was cut in two pieces along its length. You needed one cruck at each end of the building and one in the middle. This created your frame, which you then added to and filled in with mud walls and a straw thatched roof.

A Cruck frame was quick to build but it didn't have much room upstairs.

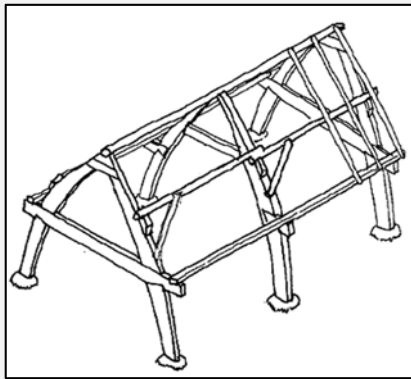

Llwyn Celyn is built with a wooden frame; timber is wood used for building. Today buildings with wooden frames are quite rare. Most were pulled down to make way for more modern buildings. They caught fire easily too. Timber houses were quick and cheap to build. Remember the story of the Three Little Pigs!

The timber from oak trees is the best for building with because it is very hard. Oak is a common tree in Britain, and it was grown especially to supply timber for building – not just houses, but ships too. You can still see big oak trees in the countryside today. They look like this, and they have wiggly leaves and acorns in the autumn.



Can you find any oak trees near LLwyn Celyn?

People who work with wood are called carpenters.

Over time, timber framed houses started to look more like boxes, with a triangle for the roof. People wanted to have proper rooms upstairs.

This is a picture of Langley Gatehouse, also owned by Landmark. The carpenter has made lovely patterns inside the basic box frame as decoration (say 'dec-or-ayshun').





Often the walls between the sections of timber frame were made of mud, with bits of straw and perhaps a bit of cow or pony poo! At Llwyn Celyn they are filled in with stone from the hillsides surrounding the farmhouse – these stones seem to come out of the earth in near perfect blocks for building!

If the grid below is your timber frame – design a pattern to make it more decorative. The carpenters were clever people and could make curves out of straight pieces of wood – so you can be as creative as you like! You can add windows and doors if you like.

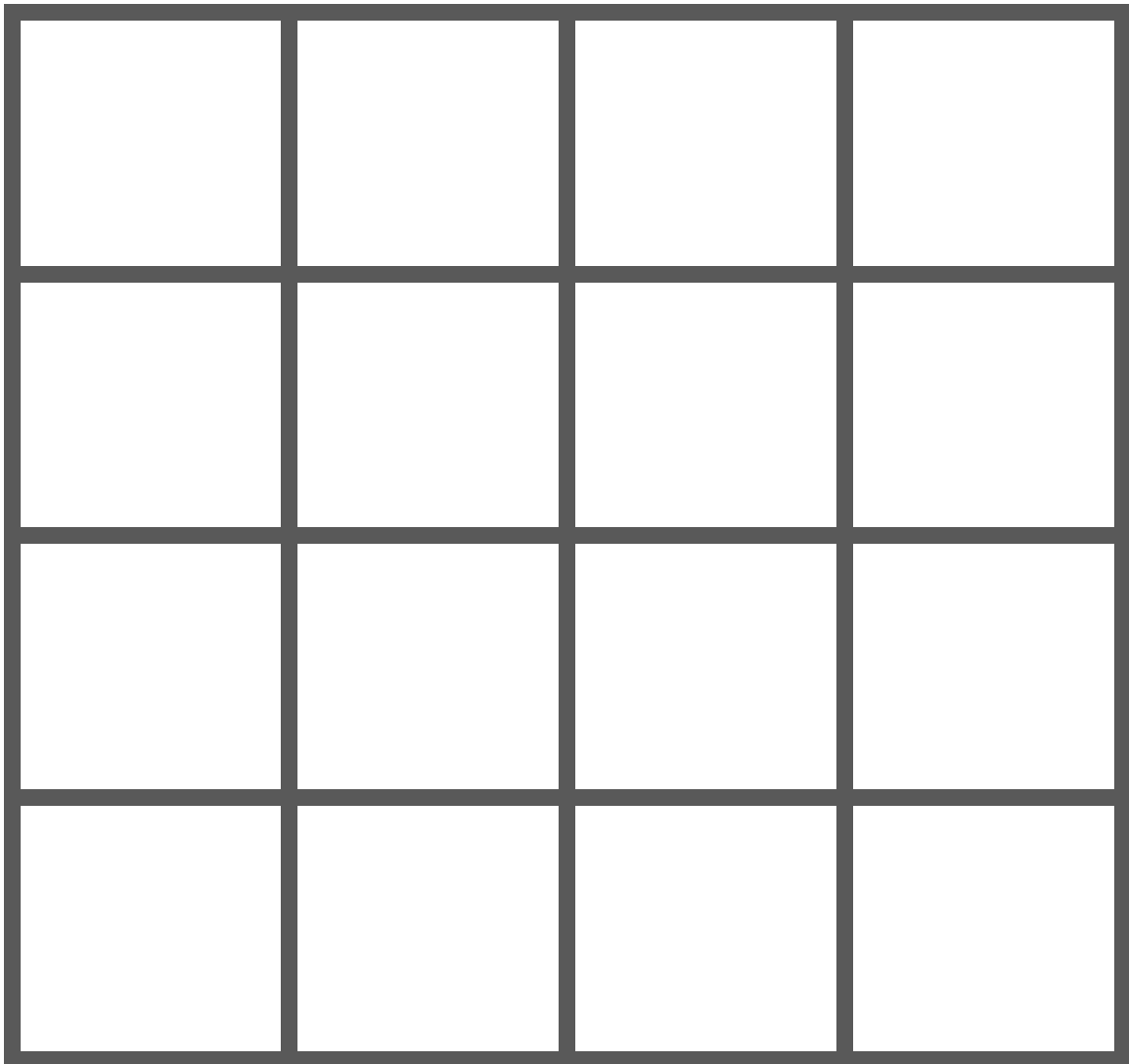

What other building materials can you find outside and inside Llwyn Celyn?

Stone

Brick

Circle what you can see and note down where you found them.

Wood

Clay

Metal

Concrete

Flint

Ceramic

Glass

Plastic



The size and shape of windows tells you a lot about the age and style of the building. What type of windows does Llwyn Celyn have?

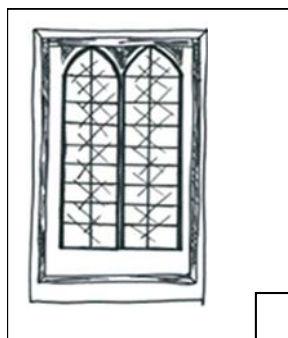

Fixed Picture

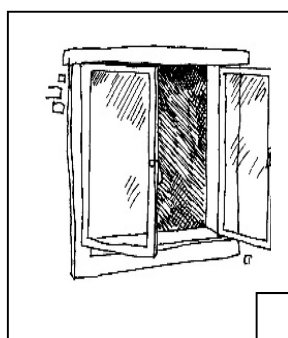

Casement

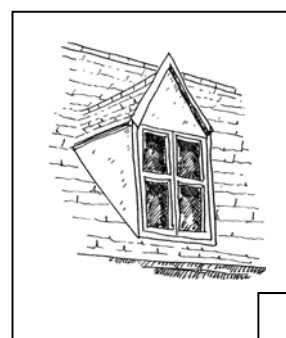

Dormer or attic

Fact:

Have you seen that in some very old buildings the windows don't open? Imagine how hot it got in the summer! When the casement window was invented it was the first type of window to open.

Entrances can be grand or simple. What is the front door of Llwyn Celyn like?

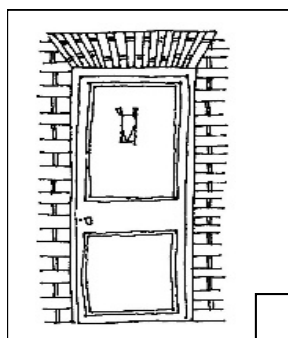

Doorframe

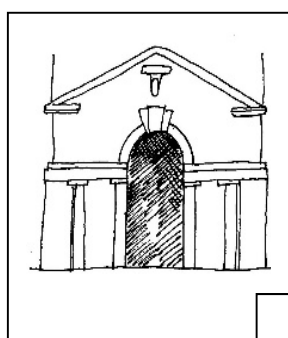

Porch

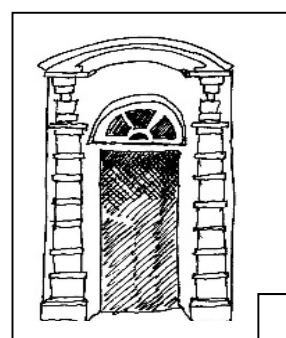

Canopy

There are many different styles of staircases. Which style is closest to the staircase at Llwyn Celyn?

Straight

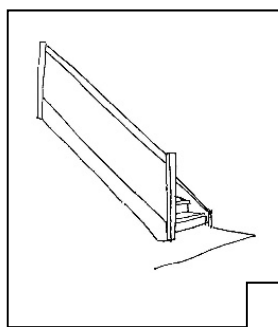

Quarter turn or dog leg

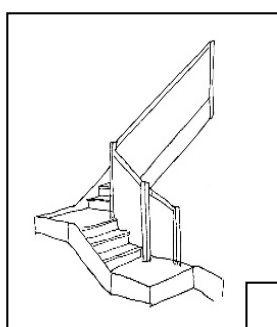

Spiral

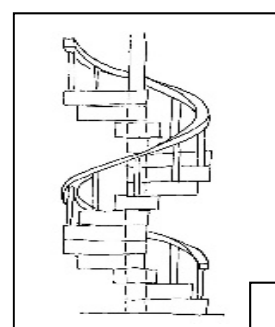

Quest



Discover more about Llwyn Celyn

Llwyn Celyn has been here in this quiet valley for almost 600 years! Follow this quest to discover more about it.

Look out for these beautiful doorheads. Have you found the one with two blank shields? Perhaps these were for displaying the arms of Llanthony Priory and its prior's personal arms.



The picture to the left shows a variation of the Llanthony Priory coat of arms. It's from a stained glass window in Bromsberrow Church. It inspired the curtain design here at Llwyn Celyn. Take a look and see if you can pick out the hand holding the holly bush. "Llwyn Celyn" means "holly bush" in Welsh.

Facts:

Did you know that when Landmark were restoring Llwyn Celyn, they found two old shoes hidden in the eaves of the roof. One of the shoes was dated back to the 17th Century! They were likely put there to protect the people living in the house from witchcraft - we've put them back in place now so you're safe too!





Living in Llwyn Celyn

The floorplan of a building is a map of the rooms. Llwyn Celyn has two floors. The plans below show you the shape of each room. Take a walk around each floor. Can you identify the rooms and write on the plan how they are used today?



Ground Floor

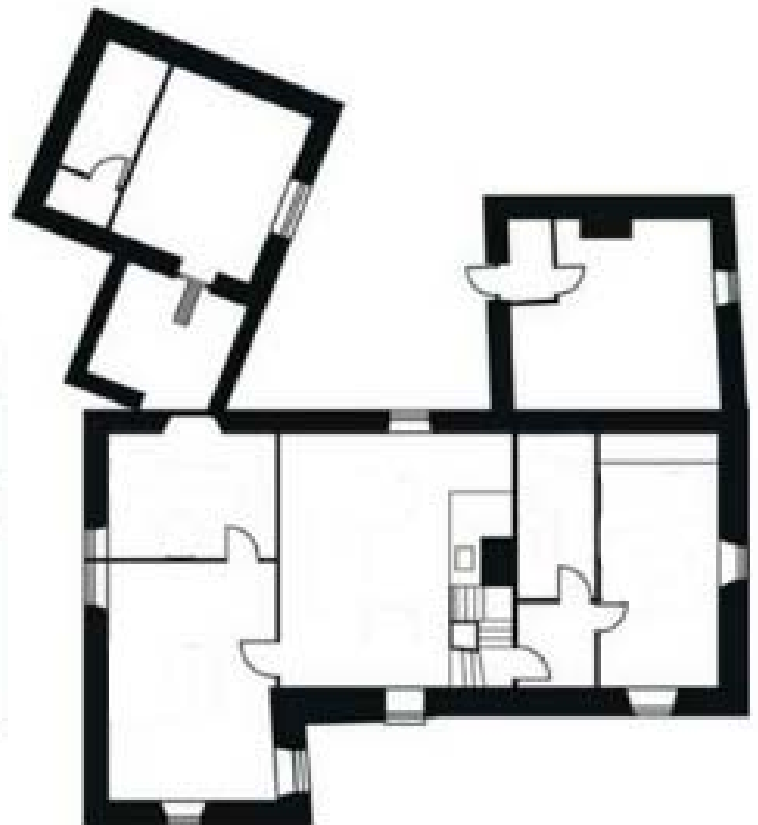

First Floor

We use these symbols to show where beds, tables and bathrooms are. Colour in the symbols on to the floorplans when you have found it in real life.



Bathroom



Cooker



Bed



Rectangular/round table

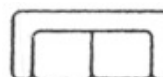

Sofa



Kitchen sink



Can you find an example of each of these things inside Llwyn Celyn. Describe, or draw the object you find it.

Your piece of furniture

The fireplace (is it an open fire or does it have a stove?)

The pattern of a rug on the floor

Fact:

HRH Prince Charles planted an apple tree in the orchard in July 2018 to celebrate the work on the house coming to an end. I wonder if you can find it?



In the space below, draw the view from your bedroom window. What can you see in the distance? any animals in the fields or any trees that look very old and interesting?



Can you answer these questions? You'll need to read the History pages first!

1. When was Llwyn Celyn built?

1310

1420

1690

1840

2. How many square meters is an acre?

4047

40

467

1000

3. Which title did Glyndwr give himself?

Lord of the Vale

King of the Welsh

Prince of Powys

Baron Glyndwr

4. When did John and Richard Gilden arrive at Llwyn Celyn?

1800

1940

2000

1675

5. What wood was the Watkins' table made from?

Oak

Pine

Birch

Elm

6. What is dendrochronology?

Science of dating
wood

A game

A chemical

An archway

7. When did Glyndwr die?

1415

1480

1550

1800

**8. Who was on the throne when Job Watkins moved to Llwyn Celyn?
(Psst.... Check Unruly Rulers)**

Henry VIII

James II

William III

Victoria

To find the answers skip two pages...



Which leaf belongs to which tree?

Match the leaf to the correct tree.

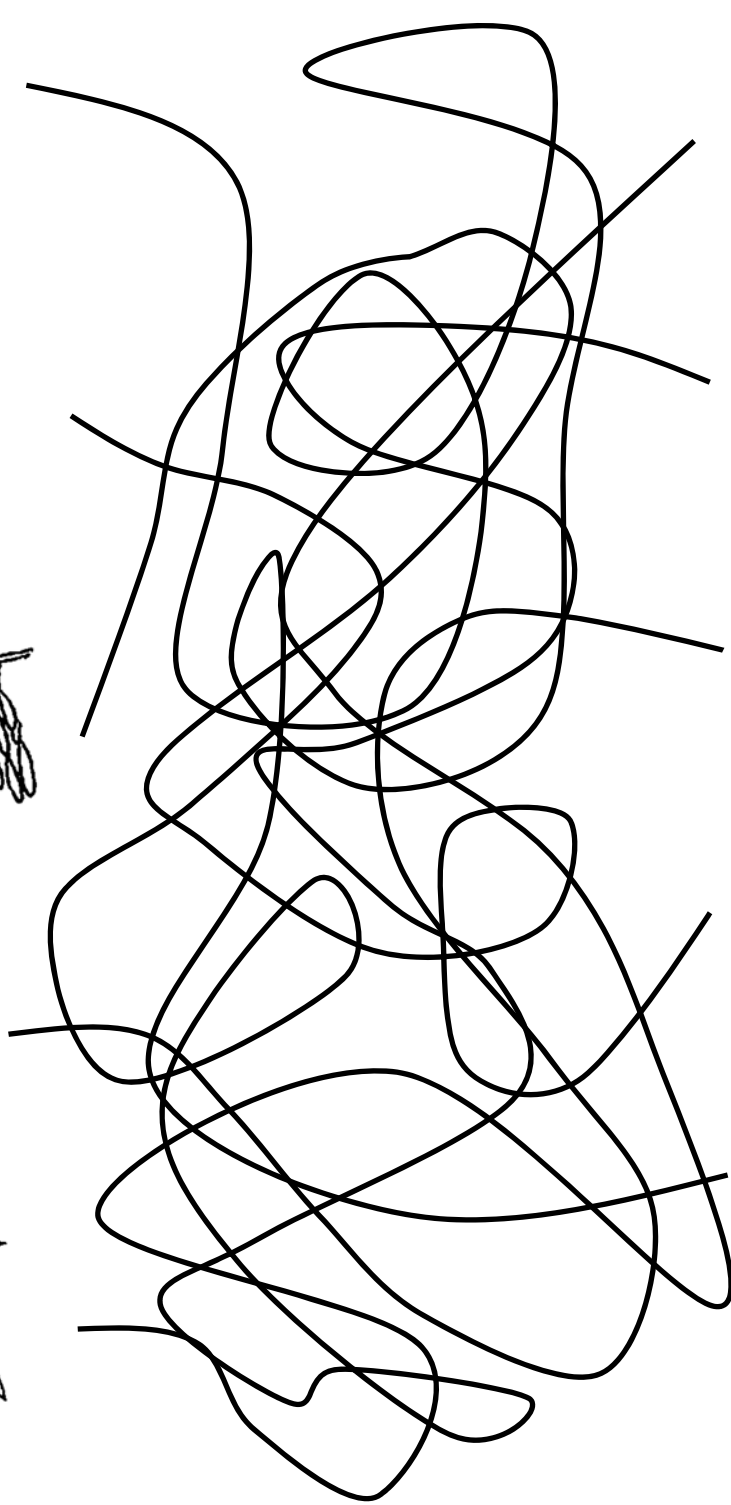

Horse Chestnut

Willow

Pine

Ash

Oak

Did you match them correctly? Put your score in the box.



Llwyn Celyn Word Search

Now have a go at the word search. Think about different parts of the building when filling in the word search. The words to find are at the bottom of the page.

P	B	Y	H	A	L	L	H	O	U	S	E	G
H	L	G	E	E	U	C	A	V	E	C	N	L
L	Y	O	Q	S	H	E	E	P	G	R	I	Y
I	E	L	M	U	H	S	H	V	X	O	K	N
V	N	O	E	O	R	A	L	O	S	S	T	D
E	M	N	D	H	L	C	M	Q	T	S	A	W
S	I	O	I	T	O	R	G	U	A	P	W	R
T	H	R	E	S	H	I	N	G	B	A	R	N
O	C	H	V	A	P	A	L	V	L	S	X	C
C	S	C	A	E	A	T	K	L	E	S	E	C
K	P	O	L	B	X	S	Y	Y	I	A	Y	A
L	O	D	G	N	I	M	R	A	F	G	X	D
X	R	N	S	S	U	R	T	E	R	E	P	S
T	C	E	L	L	A	N	T	H	O	N	Y	H
M	N	D	N	E	V	O	D	A	E	R	B	Z

FARMING

SHEEP

SPERE TRUSS

DENDOCHRONOLOGY

WATKIN

LLANTHONY

TABLE

LIVESTOCK

MEDIEVAL

BREAD OVEN

STAIRCASE

CHIMNEY

CROSS PASSAGE

SOLAR

HALLHOUSE

CROPS

GLYN DWR

EVACUEE

THRESHING BARN

BEAST HOUSE

How many of these words did you find? Put your score in the box.

20



Answer sheet:

Quiz answers:

1. 1420
2. 4047
3. Prince of Powys
4. 1940
5. Oak
6. A decorative arch
7. 1415
8. William III

How many did you get right?

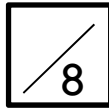

Fact:

Did you know that farming began around 10,000 BC. Wandering tribes needed food and so cleared land to grow food.

Brain teaser...

A farmer wants to cross a river and take with him a wolf, a sheep, and a cabbage.

There is a boat that can fit himself plus either the wolf, the sheep, or the cabbage.

If the wolf and the sheep are alone on one shore, the wolf will eat the sheep. If the sheep and the cabbage are alone on the shore, the sheep will eat the cabbage.

How can the farmer bring the wolf, the sheep, and the cabbage across the river?

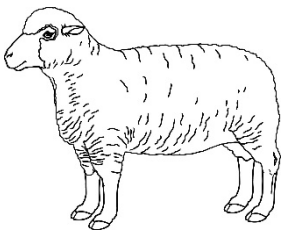

Farmer takes the sheep across (leaving wolf and cabbage behind. Wolves don't like cabbages to eat!)

Farmer returns alone

Farmer takes wolf across

Farmer returns with sheep

* We now have the Farmer, the cabbage and the sheep on one side and the wolf on the other side

Farmer takes cabbage across

Farmer returns alone

Farmer takes sheep across



Colour in this modern farmyard scene below. Can you spot what makes it modern?

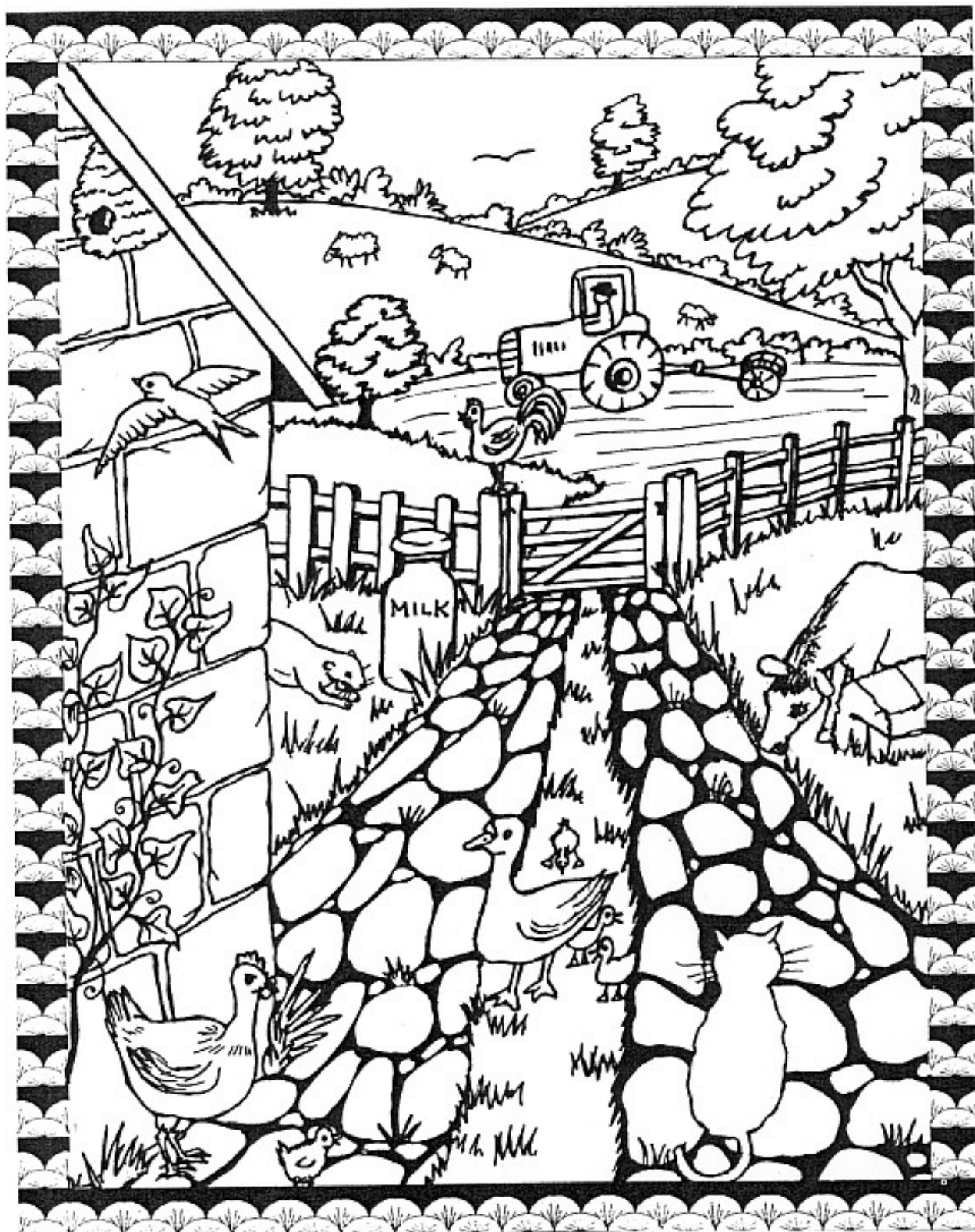



Learn a little Welsh...

Impress the people you are staying with by learning a little bit of Welsh.

Welsh can be tricky to learn as some of the letters sound different to how they would in English.

<u>English</u>	<u>Welsh</u>	<u>Pronunciation</u>
Hello	Sut mai	Sit mae
My name's	Fy enw i yw	Vuh an-oo ee yu
Goodbye	Hwyl fawr	Hueyl vowrr
You're welcome	Croeso	Kroy-ssoh
Please	Os gwelwch yndda	Os gewl-ookh uhn thah
Thank you	Diolch	Dee-olkh
How are you?	Sut ydych chi?	Sit uh-deekh keeh?

Colour in this Welsh dragon...

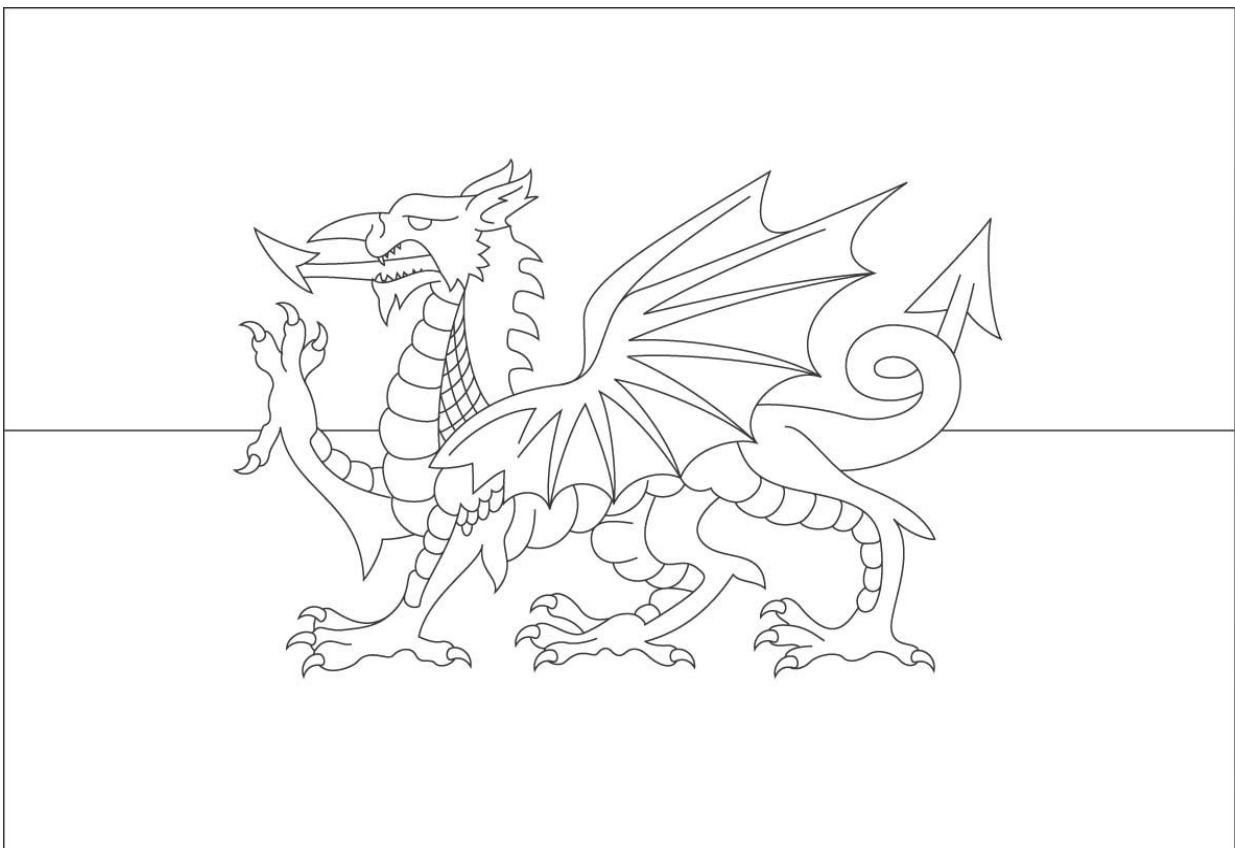



Did you know that the bats at Llwyn Celyn have their own heated roof space to roost in? Look out for them outside at dusk.

Bats are mammals like humans (except they can fly!) A mammal is a creature that breathes air, has a back bone and grows hair. They fly using their hands. Like us they have two arms and two legs. Their skin stretches from their fingers to their body which makes wings for them to fly.

Bats are nocturnal. This means they come out at night and sleep all day. They sleep hanging upside down with their feet holding them in place. If you're lucky you might see them flying as the sun sets.

It's quite hard finding food in the dark so bats use their ears to help them. They can 'see' with their ears (huh?) Bats shout as they fly and listen for echoes to bounce back to tell if something is there. That's why they have such big ears – all the better for hearing with!

FALSE MYTH ALERT: Bats aren't blind! They can see just as well as us in twilight. But they only see in black and white (it must be like watching an old movie).

In the box below draw your own bat.

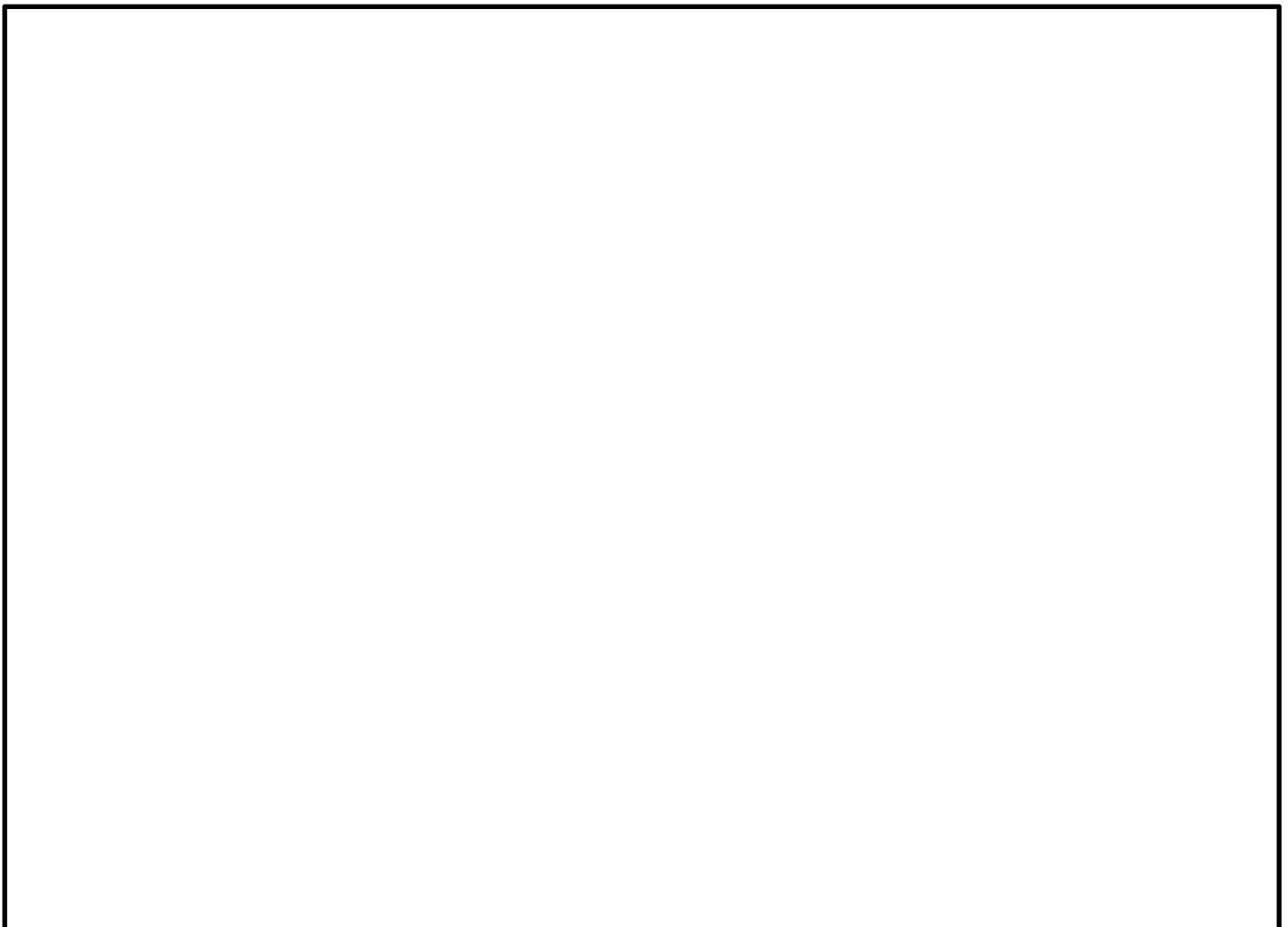



Design a curtain:

Curtain designs have to be repeated next to each other. So your design needs to be repeated identically in each box. Think about how the pattern touches the next repeat!

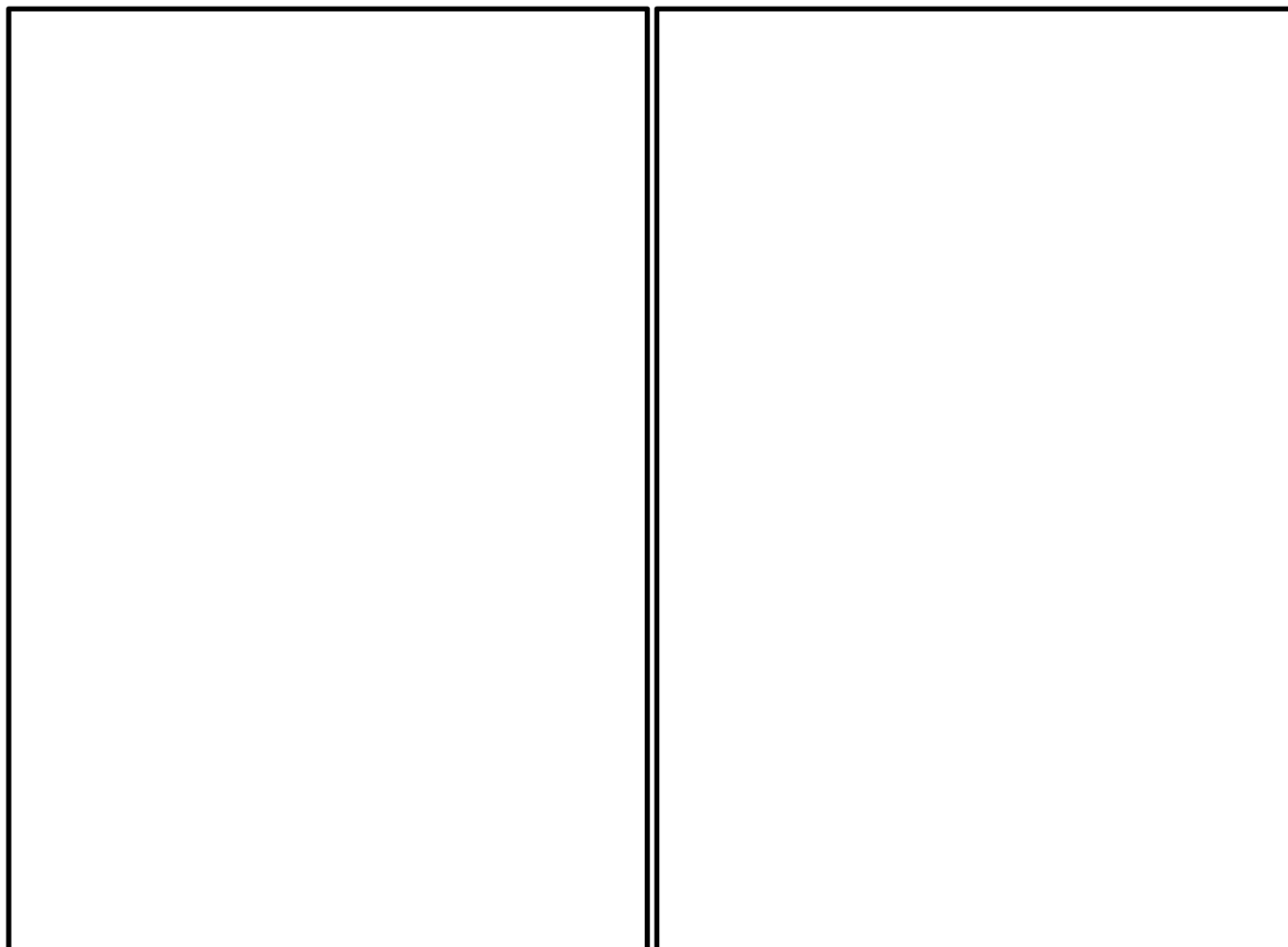

Here's an example from The Grange in Ramsgate, Kent.





Sheep marks...

Sheep graze all over the mountains so it's very important to know which farm they belong to. Each farm has its own ear mark, which are cut into the sheep's ears so the farmer could know it was his. Ouch! But the sheep don't seem to mind too much.

Make up your own ear mark and add to the blank sheep.

